



Currie

www.currietechnology.com

Customer Service (800) 377-4532

900 Scooter Exploded Parts View

EZ-900-BL
EZ-9008-BL

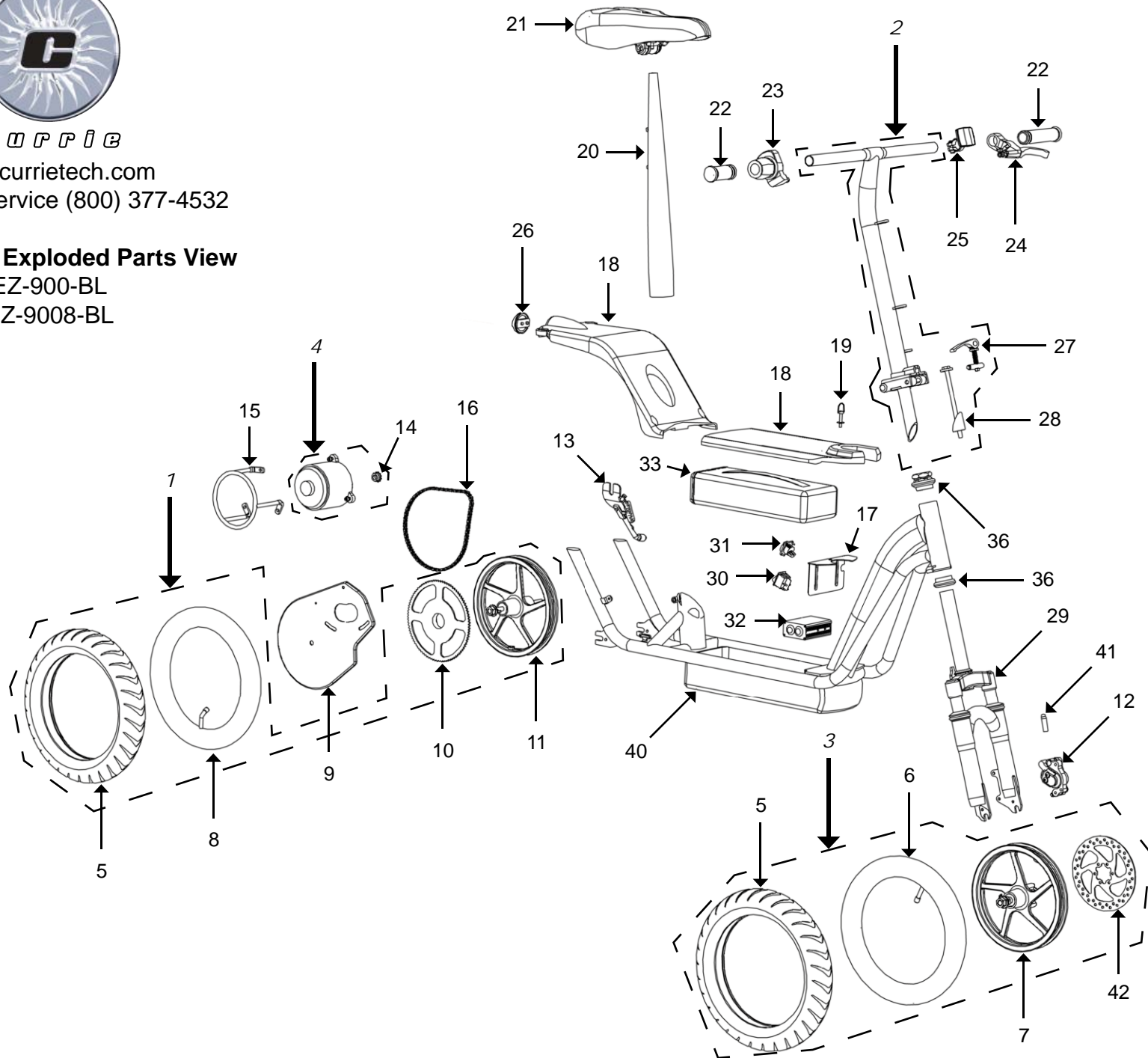

Diagram #	Description	Part #
1	Rear Wheel Assembly	WH-12R-003A
2	Handlebar Assembly	HB-FD6Q-430A
3	Front Wheel Assembly	WH-1005-3
4	Motor	MT-24900-001S
5	Tire	TT-416
6	Tube (front)	TT-421
7	Wheel (front)	WH-12F-003A
8	Tube (rear)	TT-422
9	Motor Plate	SD-5006-1
10	Sprocket	SD-350
11	Wheel (rear)	WH-916
12	Brake (disk type)	BR-YK2-002A
13	Kickstand	AS-450
14	Motor Gear	SD-250-5
15	Motor Guard	SD-185
16	Chain	SD-365
17	Controller Plate	n/a
18	Deck (Black w/out graphics)	SF-1506-1
19	Deck Quick Release Screw	SF-450-2
20	Seat Tube	SU-500480-887
21	Seat	SE-CL7810
22	Grips (left & right)	AS-355-2
23	Throttle	TH-XH2DL-002A
24	Brake Lever w/ Inhibitor	BL-H430AD-L02
25	Reflector (front)	AS-460
26	Reflector (rear)	AS-965
27	Handlebar Quick Release	AS-321-1
28	Stem Bolt & Wedge	HW-BW-005
29	Fork (Black w/out graphics)	FK-ALFK15-YS728
30	Switch	BA-080
31	Charger Port	BA-071-7
32	Controller	CT-2430-002A
33	Battery Pack	BA-PK24-002A
34	Wire Harness - Complete (not shown)	WR-DME090C
35	Brake Cable (not shown)	SP-910
36	Headset	n/a
37	Fuse (not shown)	AU-062

Diagram #	Description	Part #
38	Charger (not shown)	AU-097
39	Charger (Fast) Optional (not shown)	AU-092-4
40	Frame	n/a
41	Brake Power Modulator	BR-PC380A-001A
42	Brake Disk Rotor (style may differ from shown)	BR-ZDA160Z

