

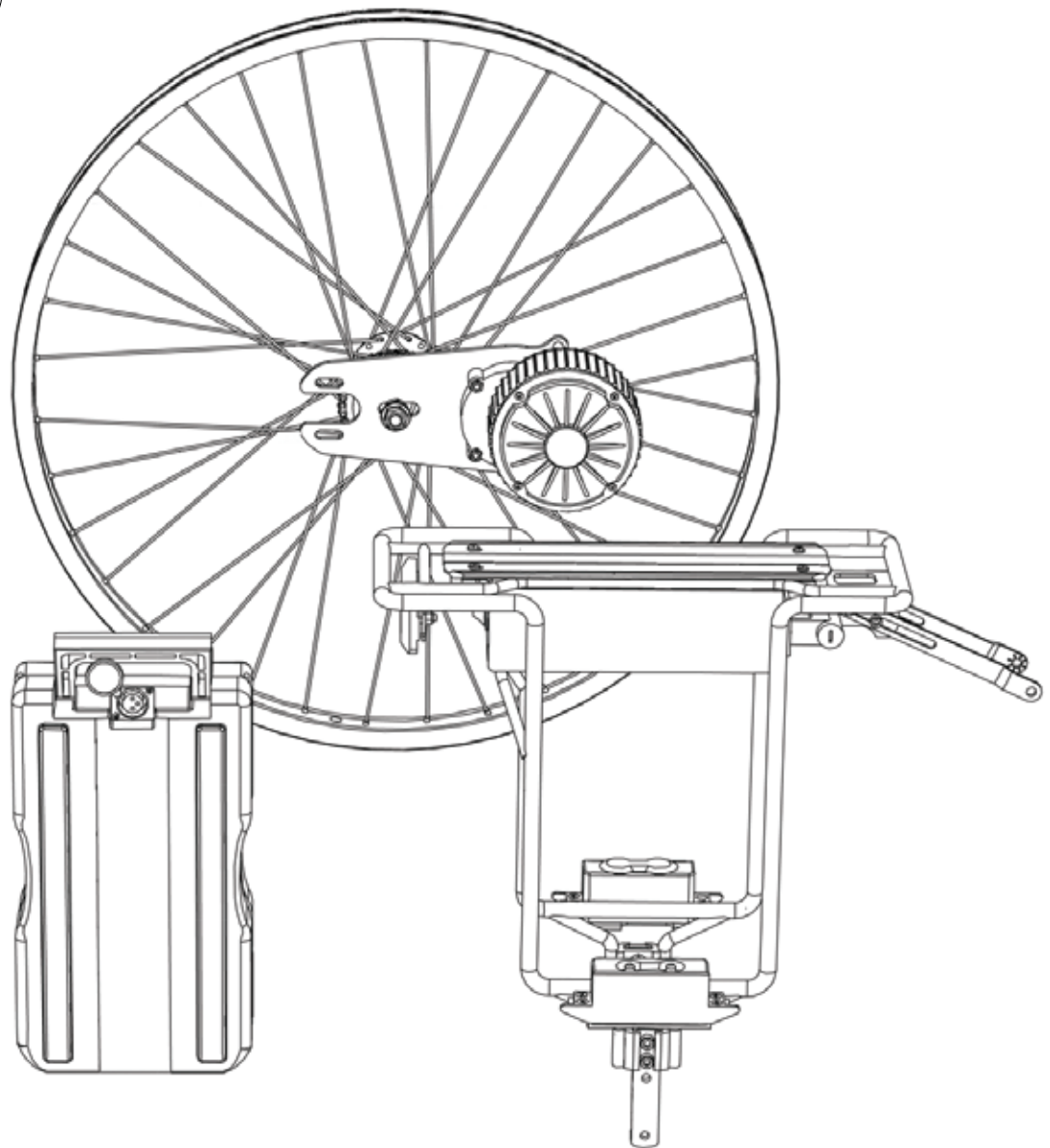

Currie Electro-Drive[®] Conversion Kit with 24V / 10Ah SLA RMB Battery Pack INSTALLATION GUIDE



Before You Start...

Bicycle Prerequisites:

Bicycles to be converted must:

- Use a 5,6, or 7-speed rear freewheel
- Have rear dropout rack/fender mounting holes or eyelets
- Use standard, 26" wheels (ISO 559, 26x1.5 - 2.125)
- Have 135mm rear axle spacing
- Have standard, straight seat stays (kit is not designed to fit wishbone-style stays)

Parts Included:

- RMB Rack assembly
- 24V / 10Ah SLA battery pack
- Battery charger
- 26" wheel, with Direct Drive motor, left-side freewheel (single), chain
- Mounting Brackets:

- Motor plate retention bracket



- Motor plate back bracket



- Seat stay rack mount bracket x2

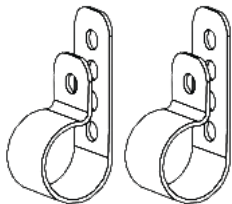

- Throttle, thumb control w/ battery status indicator
- System controller unit

Required Tools:

- Allen wrenches
 - 2.5mm, 4mm, 5mm, 6mm
- Phillips head screwdriver
- Box wrenches
 - 10mm, 15mm, 17mm
- Bicycle tire levers (Plastic type)
- Bicycle tire pump
- Freewheel remover (Type varies, see your bike's instruction manual for more info.)
- Large adjustable wrench (to operate freewheel remover)

Installation of this conversion kit requires advanced bicycle mechanic skills, including:

- Derailleur adjustment
- Brake adjustment
- Tire removal & installation
- Freewheel removal & installation
- General mechanical aptitude

Please consider having your local bicycle shop install the kit if you aren't sure you can do it safely



CURRIE TECHNOLOGIES
Hybrid Electric Bicycles & Scooters

9453 Owensmouth Ave., Chatsworth, CA 91311 USA
Phone: +1 800 377 4532 | Fax: +1 818 734 8199
currietechnology.com | izipusa.com | ezipusa.com
sales@currietechnology.com | sales@izipusa.com

Initial Setup...

1

Remove the rear wheel from the bicycle to be converted



2

Remove the wheel's tire, tube, freewheel, and spoke protector



3

Install your hardware from step 2 onto the conversion kit wheel



4

Set the drive chain's tension by sliding the motor away from the axle, then tighten the 17mm bolt shown to secure it



CURRIE TECHNOLOGIES
Hybrid Electric Bicycles & Scooters

9453 Owensmouth Ave., Chatsworth, CA 91311 USA
Phone: +1 800 377 4532 | Fax: +1 818 734 8199
currietech.com | izipusa.com | ezipusa.com
sales@currietech.com | sales@zipusa.com

IZIP-KIT1 Installation Guide 2010

Bike Prep...

5

Install the new rear wheel. The bike's chain stay will fit into the slot on the motor plate. You may need to pull the left-side stays outward initially to allow the plate to clear as you insert it



6

The motor plate is secured by the two brackets shown. You will need to re-size these brackets using pliers and/or a vice to fit your bike's specific geometry and tube diameters

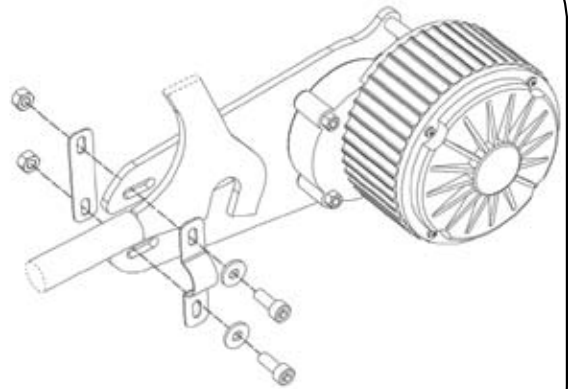

7

The completed rear wheel setup.



8

Bend-to-fit and install the two seat stay mounting brackets. This step is only necessary on bikes without pre-drilled mounting holes



9

At this time, you should re-adjust your rear derailleur and rear brakes. Check them for proper operation before riding



CURRIE TECHNOLOGIES
Hybrid Electric Bicycles & Scooters

9453 Owensmouth Ave., Chatsworth, CA 91311 USA
Phone: +1 800 377 4532 | Fax: +1 818 734 8199
currietechnology.com | izipusa.com | ezipusa.com
sales@currietechnology.com | sales@izipusa.com

Rack Installation...

10

The rack is pre-assembled from the factory as shown

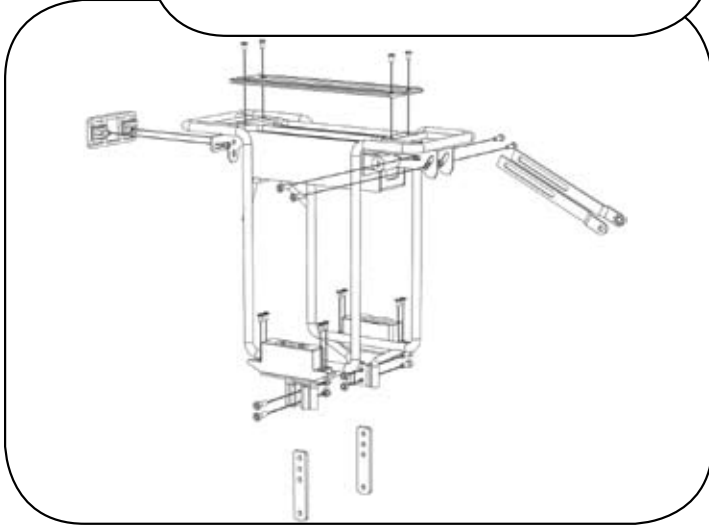

11

Bolt the base of the rack onto the bicycle's dropouts



12

Bolt the rack's arms to the seat stay brackets (a), or to bike's seat stay mounting holes if available (b)

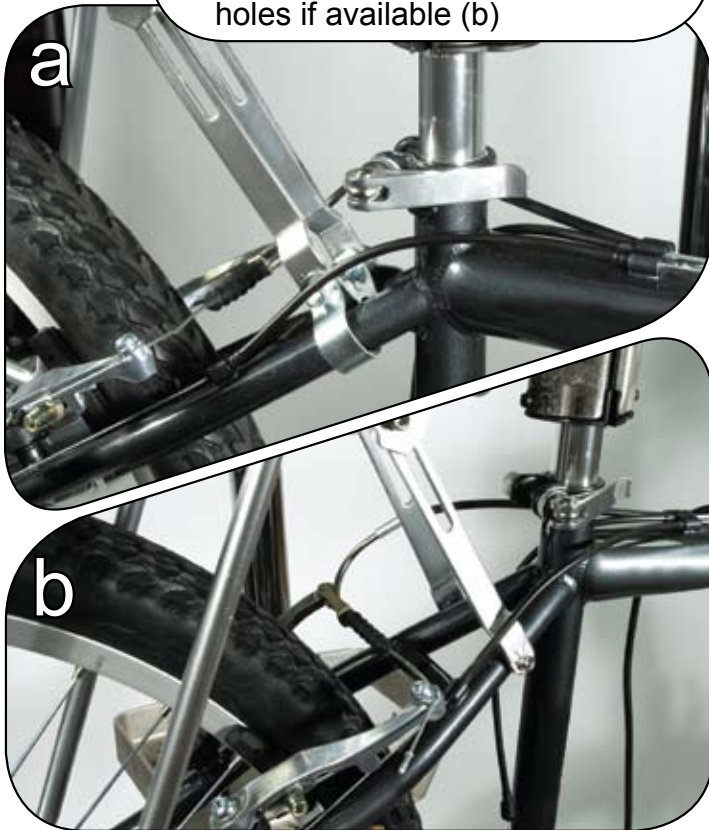

13

Make sure the rack is level to the ground. If necessary, it can be raised or lowered at the dropout mount (a), and tilted by adjusting the seat stay mount arms (b)

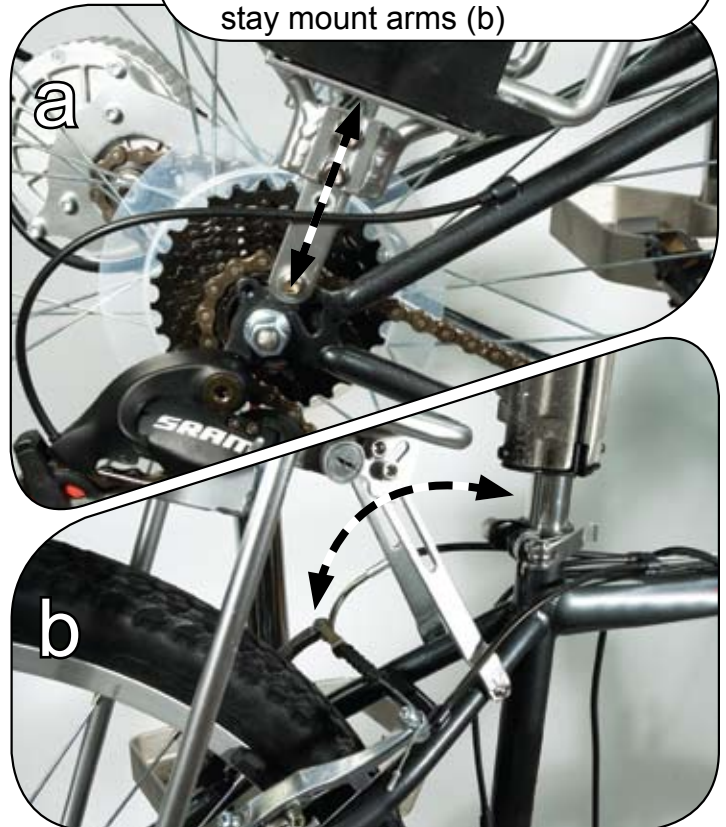

CURRIE TECHNOLOGIES
Hybrid Electric Bicycles & Scooters

9453 Owensmouth Ave., Chatsworth, CA 91311 USA
Phone: +1 800 377 4532 | Fax: +1 818 734 8199
currietech.com | izipusa.com | ezipusa.com
sales@currietech.com | sales@zipusa.com

IZIP-KIT1 Installation Guide 2010

Electrical Installation...

14

Install the throttle on the handlebars (right side). The throttle should be the innermost attachment so it does not interfere with braking



15

Connect the throttle and motor wires to complete the electrical system. If any problems arise, check the pre-assembled wire harness against the following diagram

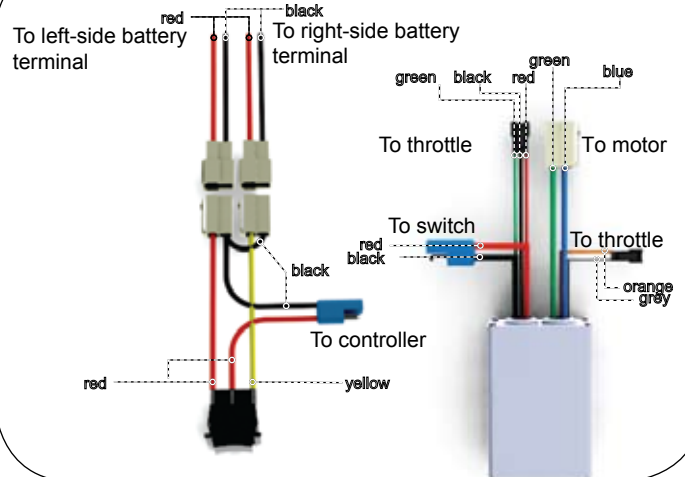

16

Route the terminal and motor wires into the rack box, through the hole between the support arms. The wires should be zip-tied along the seat stays and not allowed to hang near the wheel or brakes



17

Secure all wires and connectors inside the rack box, then attach the top plate with the four screws shown



CURRIE TECHNOLOGIES
Hybrid Electric Bicycles & Scooters

9453 Owensmouth Ave., Chatsworth, CA 91311 USA
Phone: +1 800 377 4532 | Fax: +1 818 734 8199
currietech.com | izipusa.com | ezipusa.com
sales@currietech.com | sales@zipusa.com

IZIP-KIT1 Installation Guide 2010

Final Setup...

18

Slide the battery into either side of the rack. Lock it in place with the provided key to ensure that it remains in contact with the terminals



19

Charge the battery (8 hours initially, then 6-8 hours after each ride). The battery can be charged on or off the bike



20

Before your first ride, re-check your brakes and shifters and be sure the screws securing the rack are tightened properly



21

To power-on the bike, flip the battery selector (behind the rear reflector) to the appropriate side



CURRIE TECHNOLOGIES
Hybrid Electric Bicycles & Scooters

9453 Owensmouth Ave., Chatsworth, CA 91311 USA
Phone: +1 800 377 4532 | Fax: +1 818 734 8199
currietech.com | izipusa.com | ezipusa.com
sales@currietech.com | sales@zipusa.com